

# ATN PS-22

## NIGHT VISION FRONT SIGHT



OPERATOR'S MANUAL (ATN PS-22) REVISION 6 - MARCH 2011

## *operator's manual*

**Important Export Restrictions!** Commodities, products, technologies and services contained in this manual are subject to one or more of the export control laws and regulations of the U.S. Government and they fall under the control jurisdiction of either the US Department of State or the US BIS-Department of Commerce. It is unlawful and strictly prohibited to export, or attempt to export or otherwise transfer or sell any hardware or technical data or furnish any service to any foreign person, whether abroad or in the United States, for which a license or written approval of the U.S. Government is required, without first obtaining the required license or written approval from the Department of the U.S. Government having jurisdiction. Diversion contrary to U.S. law is prohibited.



**AMERICAN  
TECHNOLOGIES  
NETWORK  
CORP.**

**Register your product warranty online at  
[www.atncorp.com/warranty](http://www.atncorp.com/warranty)**

The information in this manual furnished for information use only, is subject to change without notice, is not to be construed as a commitment by ATN Corp. ATN Corp. assumes no responsibility or liability for any errors or inaccuracies that may appear in this book.

© 2011 ATN Corp. All right reserved.

# SAFETY SUMMARY

---

## STUDY CAREFULLY THIS MANUAL BEFORE TURNING ON AND OPERATING THIS PRODUCT.

### CAUTIONS

The ATN PS-22 night vision front sight is a precision electro-optical instrument and requires careful handling. To provide safe use of the sight the following instructions should be observed:

- Do not dismantle the sight.
- Keep the sight clean; protect it from moisture, sharp temperature drops and shocks.
- Be careful not to touch the glass surfaces. If you put fingerprints on, or contaminate the glass surfaces, use only clean and soft materials to clean it.
- Protect the sight from a light overloading. Do not turn the sight on in daylight with the Front Lens Cap off. Do not point the sight at the bright light source (a fire, car headlights, lanterns, street lamps, room lights, etc.).
- Do not leave the sight in on position during stops in operation.
- Remove the battery from the sight for the period of storage.

## CAUTION:

**THIS PRODUCT CONTAINS NATURAL RUBBER LATEX WHICH MAY CAUSE ALLERGIC REACTIONS.**

## **NOTES**

- **Do not test the device in daylight conditions even with the daylight filter/lens cap on for more than ten (10) minutes.**
- **To protect the device from damage do not direct it to the bright light sources (a fire, headlights of the automobile, lanterns, etc.).**

## **EQUIPMENT LIMITATIONS**

To avoid physical and equipment damage when using the ATN PS-22, carefully read and understand the following equipment limitations.

- The equipment requires some night light (moonlight, starlight, etc.) to operate. The level of equipment performance depends upon the level of light.
- Night light reduces by passing through the clouds, while operating under trees, at building shadows, etc.
- The equipment is less effective when viewing into shadows and other darkened areas.
- The equipment is less effective when viewing through the rain, fog, sleet, snow or smoke.
- The equipment will not “see” through the dense smoke.

# TABLE OF CONTENTS

---

	pg.
<b>SAFETY SUMMARY</b>	<b>a</b>
<b>SECTION I. INTRODUCTION</b>	<b>1-1</b>
<b>1.1. General</b>	<b>1-2</b>
1.1.1. Scope	1-2
1.1.2. Reports	1-2
1.1.3. Storage	1-2
1.1.4. Warranty	1-3
<b>1.2. Description and Data</b>	<b>1-5</b>
1.2.1. Description	1-5
1.2.2. PS-22 Standard Components and Optional Equipment	1-8
<b>SECTION II. OPERATING INSTRUCTIONS</b>	<b>2-1</b>
<b>2.1. Installation Procedures</b>	<b>2-2</b>
2.1.1. Quick Release Mount	2-2
2.1.2. Attachment to Day Scope Objective	2-3
2.1.3. Extender Focus Knob	2-7
<b>2.2. Operating Procedures</b>	<b>2-8</b>
2.2.1. General	2-8
2.2.2. Controls	2-8
2.2.3. Operating Procedures	2-10
2.2.4. Stowage of PS-22	2-11
<b>2.3. Installation and Use of Accessories</b>	<b>2-12</b>
2.3.1. 7/8" Weaver Mount	2-12
2.3.2. Remote Control	2-12
2.3.3. Picatinny Rail	2-13
2.3.4. Platform Ring	2-14
2.3.5. Long Rail Adapter	2-14
2.3.6. B.A.M. System	2-14
2.3.7. IR450 Illuminator	2-16
2.3.8. Day Scope Light Suppressor	2-18

<b>SECTION III. OPERATIONAL DEFECTS</b>	<b>3-1</b>
<b>3.1. Zeroing Operational Defects</b>	<b>3-2</b>
3.1.1. Shading	3-2
3.1.2. Edge Glow	3-3
3.1.3. Flashing, Flickering, or Intermittent Operation	3-3
3.1.4. Cosmetic Blemishes	3-3
<b>SECTION IV. MAINTENANCE INSTRUCTIONS</b>	<b>4-1</b>
<b>4.1. Preventive Maintenance Checks and Services (PMCS)</b>	<b>4-2</b>
4.1.1. Purpose of PMCS	4-2
4.1.2. PMCS Procedures	4-2
<b>4.2. Troubleshooting</b>	<b>4-5</b>
4.2.1. General	4-5
4.2.2. Troubleshooting Procedures	4-5
<b>4.3. Maintenance Procedures</b>	<b>4-7</b>
4.3.1. PS-22 Maintenance	4-7
4.3.2. Cleaning Procedures	4-7
4.3.3. Tube Maintenance / Replacement	4-8
<b>Appendix A. Estimation of Ambient Illumination Level</b>	<b>A-1</b>
<b>Appendix B. Spare Parts List</b>	<b>B-1</b>
<b>Appendix C. How to select Scope Mounting System For Technical Information</b>	<b>C-1</b>
	<b>INFO-1</b>



# **SECTION I**

## **INTRODUCTION**

# **1.1 GENERAL INFORMATION**

---

## **1.1.1. SCOPE**

This manual contains instructions for use in operating and maintaining the ATN PS-22 Night Vision Front Sight. Throughout this manual, the ATN PS-22 will be referred to as the sight or the PS-22.

## **1.1.2. REPORTS**

Reports from the user on recommendations for improvements are encouraged. Send reports to the address below.

American Technologies Network Corp.  
1341 San Mateo Avenue  
South San Francisco, CA 94080  
(800) 910-2862  
(650) 989-5100  
(650) 875-0129 fax  
[www.atncorp.com](http://www.atncorp.com)  
[info@atncorp.com](mailto:info@atncorp.com)

## **1.1.3. STORAGE**

Storage of the PS-22 should be done in the factory packing and after a thorough PMCS as outlined in Section 4 of this manual. This will ensure the sight remains in mission ready condition during storage. Battery should be stored separately from the sight.

The PS-22 should not be placed on the floor, in any area exposed to high temperatures or direct sunlight. Presence of acid and alkaline vapor, as well as of other aggressive admixtures in the air is unacceptable.

## 1.1.4. WARRANTY

### 2 YEAR PRODUCT WARRANTY

This product is guaranteed to be free from manufacturing defects in material and workmanship under normal use for a period of 2 (two) years from the date of purchase. In the event a defect that is covered by the foregoing warranty occurs during the applicable period stated above, ATN, at its option, will either repair or replace the product, and such action on the part of ATN shall be the full extent of ATN's liability, and the Customer's sole and exclusive remedy. This warranty does not cover a product (a) used in other than its normal and customary manner; (b) subjected to misuse; (c) subjected to alterations, modifications or repairs by the Customer or by any party other than ATN without prior written consent of ATN; (d) special order or "close-out" merchandise or merchandise sold "as-is" by either ATN or the ATN dealer; or (e) merchandise that has been discontinued by the manufacturer and either parts or replacement units are not available due to reasons beyond the control of ATN. ATN shall not be responsible for any defects or damage that in ATN's opinion is a result from the mishandling, abuse, misuse, improper storage or improper operation, including use in conjunction with equipment which is electrically or mechanically incompatible with or of inferior quality to the product, as well as failure to maintain the environmental conditions specified by the manufacturer. **CUSTOMER IS HEREBY NOTIFIED THAT OPERATION OF THE EQUIPMENT DURING DAYLIGHT HOURS OR UNDER ANY EXCESSIVE LIGHT CONDITIONS MAY PERMANENTLY DAMAGE THE INTERNAL COMPONENTS OF THE UNIT AND SAID DAMAGE WILL NOT BE COVERED UNDER THIS WARRANTY.** This warranty is extended only to the original purchaser. Any breach of this warranty shall be waived unless the customer notifies ATN at the address noted below within the applicable warranty period.

The customer understands and agrees that except for the foregoing warranty, no other warranties written or oral, statutory, expressed or implied, including any implied warranty of merchantability or fitness for a particular purpose, shall apply to the product. All such implied warranties are hereby and expressly disclaimed.

### LIMITATION OF LIABILITY

ATN will not be liable for any claims, actions, suits, proceedings, costs, expenses, damages or liabilities arising out of the use of this product. Operation and use of the product are the sole responsibility of the Customer. ATN's sole undertaking is limited to providing the products and services outlined herein in accordance with the terms and conditions of this Agreement. The provision of products sold and services performed by ATN to the Customer shall not be interpreted, construed, or regarded, either expressly or implied, as being for the benefit of or creating

any obligation toward any third party of legal entity outside ATN and the Customer; ATN's obligations under this Agreement extend solely to the Customer.

**ATN's liability hereunder for damages, regardless of the form or action, shall not exceed the fees or other charges paid to ATN by the customer or customer's dealer. ATN shall not, in any event, be liable for special, indirect, incidental, or consequential damages, including, but not limited to, lost income, lost revenue, or lost profit, whether such damages were foreseeable or not at the time of purchase, and whether or not such damages arise out of a breach of warranty, a breach of agreement, negligence, strict liability or any other theory of liability.**

## **PRODUCT WARRANTY REGISTRATION**

In order to validate the warranty on your product, ATN must receive a completed Product Warranty Registration Card for each unit or complete warranty registration on our website at [www.atncorp.com](http://www.atncorp.com). Please complete the included form and immediately mail it to our Service Center: ATN Corporation, 1341 San Mateo Avenue, South San Francisco, CA 94080.

## **OBTAINING WARRANTY SERVICE**

To obtain warranty service on your unit, End-user must notify ATN service department by calling **800-910-2862** or **650-989-5100** or via e-mail **[service@atncorp.com](mailto:service@atncorp.com)** to receive a Return Merchandise Authorization number (RMA).

When returning please take or send the product, postage paid, with a copy of your sales receipt to our service center, ATN Corporation at the address noted above. All merchandise must be fully insured with the correct postage; ATN will not be responsible for improper postage or, missing or damaged merchandise during shipment.

When sending product back, please clearly mark the RMA# on the outside of the shipping box. Please include a letter that indicates your RMA#, Name, Return Address, reason for service return, Contact information such as valid telephone numbers and/or e-mail address and proof of purchases that will help us to establish the valid start date of the warranty. Product merchandise returns that do not have an RMA listed may be refused or a significant delay in processing may occur.

Estimated Warranty service time is 10-20 business days. End-user/customer is responsible for postage to ATN for warranty service. ATN will cover return postage/shipping to continental USA end-users/customers after warranty repair only if product is covered by aforementioned warranty. ATN will return product after warranty service by domestic UPS ground and/or domestic mail. Any other requested, required or international shipping method the postage/shipping fee will be the responsibility of the end-user/customer.

## **1.2. DESCRIPTION AND DATA**

---

### **1.2.1. DESCRIPTION**

#### **A. Purpose**

The PS-22 is an effective night vision system that mounts forward of an existing riflescope/spotting scope (further referred to as a scope) adding night vision capabilities to daytime target acquisition platform. Advisable dayscope magnification is 1X to 6X (2.5X to 4X is optimum). The sight is installed and removed without affecting boresight (permanent boresight alignment).

#### **NOTE**

**The PS-22 can be installed also forward of viewfinders of various instruments to widen operating illumination range.**

#### **B. Principle of Operation**

The PS-22 operation is based on the principle of electron-optical intensification of light. The input fast catadioptric lens collects available ambient light from source such as the moon, stars and skyglow and focuses it on the image intensifier tube photocathode. The tube amplifies the light and produces the viewable image projected by the output lens from the tube screen into the dayscope lens. Thus the sight provides the capability for operator to see through the scope at night.

#### **C. Features and Limitations**

The PS-22 has the following important features:

- Available with 2+, CGT, HPT or 3rd generation image intensifier tube.
- Powered by a single CR 123A battery.
- Adjusts for lens focus.
- Is mounted on MIL-STD-1913/Picatinny rail or dayscope lens.
- Equipped with remote control.
- Is submersible to 10 m for 30 minutes.
- Filled with dry nitrogen to prevent internal fogging.

The PS-22 is an effective night vision system designed for night operations but does have following limitations:

- The sight requires some night light (moonlight, starlight, etc.) to operate. Night light is reduced by such factors as passing cloud cover and objects that produce shadows.
- The sight is less effective viewing through rain, fog, sleet, snow, smoke.
- Under starlight conditions low contrast environments (such as snow-covered territory, sandy deserts, large bodies of water or grassy hills) degrade visibility thereby disguising or masking changes in terrain.
- Under too low-light conditions the sight loses some of the resolution that it has under full moon.

**TABLE 1-1. SYSTEM DATA**

ITEM	DATA
Magnification	Unity (1X)
Boresight Characteristics:	
Accuracy	Factory aligned to ½ MOA or better
Retention	Permanent to within 1 MOA or better
Repeatability	Within ½ MOA
System Resolution subject to Tube Resolution:	
36 to 44 lp/mm	0.38 mrad/lp
45 to 54 lp/mm	0.30 mrad/lp
55 to 64 lp/mm	0.25 mrad/lp
Over 65 lp/mm	0.21 mrad/lp

**TABLE 1-2. MECHANICAL DATA**

ITEM	DATA
Dimensions(Length x Width x Height)	150 mm x 80 mm x 72 mm
Weight:	
without Battery	0.64 kg
with Remote Control, Light Suppressor and Battery	0.7 kg
Height of the Sight Axis above Arm Rail:	
with Issued Mount	40 mm

**TABLE 1-3. ELECTRICAL DATA**

ITEM	DATA
Battery	123A Lithium
Consumption Current	26 mA
Cell Life at 20 °C	50 hours

**NOTE**

**CR 123A batteries are “dead” at 2.5 VDC under load.**

**TABLE 1-4. OPTICAL DATA**

ITEM	DATA
Objective Lens Focal Length	80 mm
Objective Lens F/number	1:1.23
Objective Lens T/number	1:1.8
Focus Range	10 m to infinity
Field of View	12°
Output Lens Exit Pupil Diameter	21 mm

**TABLE 1-5. ENVIRONMENTAL DATA**

ITEM	DATA
Operating Temperature	-20 to +50 °C
Storage Temperature	-50 to +50 °C
Humidity	95 %, 25 °C to 40 °C for 48 hours
Illumination Required	Natural night illumination (overcast starlight to moonlight)
Immersion	10 m for 30 minutes

### 1.2.2. PS-22 STANDARD COMPONENTS AND OPTIONAL EQUIPMENT

The PS-22 standard components are shown in Figure 1-1 and presented in Table 1-6.



**FIGURE 1-1. PS-22 STANDARD COMPONENTS**

**TABLE 1-6. PS-22 STANDARD COMPONENTS**

ITEM	DESCRIPTION	QTY
1	Front Lens Cap	1
2	ATN PS-22 Night Vision Front Sight	1
3	Back Cap	1
4	Light Suppressor for the scopes with 30-42 mm lens diameter	1

ITEM	DESCRIPTION	QTY
5	Light Suppressor for Trijicon ACOG scopes	1
6	Light Suppressor for the scopes with 42-63 mm lens diameter	1
7	Remote Control	1
8	CR123A type battery	1
9	IR Illuminator IR450 Kit	1
10	Picatinny Quick Release Mount	1
11	Picatinny Rail	1
12	QRM Wrench	1
13	2.5 mm Allen Key	1
14	Operator's Manual	1
15	Shipping/Storage Case	1

R450-B4 IR Illuminator Kit is shown in Figure 1-2 and listed in Table 1-7.



**FIGURE 1-2. IR450 IR ILLUMINATOR KIT**

**TABLE 1-7. IR450 KIT**

ITEM	DESCRIPTION	QTY
1	IR450-B4 Illuminator	1
2	CR123A type battery	1
3	1,5 mm Allen Key	1
4	IR450 Wrench	1

Optional items are shown in Figure 1-3 and listed in Table 1-8.

**TABLE 1-8. PS-22 OPTIONAL EQUIPMENT**

ITEM	DESCRIPTION	PART CODE
1	Scope Mounting System #1	ACDNPS22SM01
2	Scope Mounting System #2	ACDNPS22SM02
3	Scope Mounting System #3	ACDNPS22SM03
4	Scope Mounting System #4	ACDNPS22SM04
5	Scope Mounting System #6	ACDNPS22SM06
6	7/8" Weaver Mount	ACDNPS22MWVR
7	Day Scope Light Suppressor	ACDNPS22LSR
8	Platform Ring	ACWSRTRA
9	Extender Focus Knob	ACDNPS22EFK
10	Boresight Attachment Mount (BAM)	ACDNPS22BM01
11	Long Rail Adapter	ACWSLRADPT

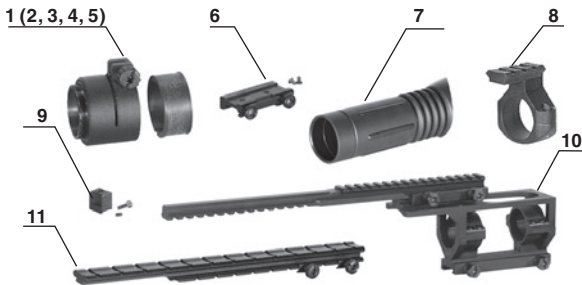

**FIGURE 1-3. PS-22 OPTIONAL EQUIPMENT**

## **SECTION II**

# **OPERATING INSTRUCTIONS**

## 2.1. INSTALLATION PROCEDURES

### 2.1.1. QUICK RELEASE MOUNT

Quick Release Mount (QRM) is used for fast installation/removing the PS-22 on MIL-STD-1913/Picatinny rail.

#### **NOTE**

Optical axes of the PS-22 and the riflescope should be matched. Difference of the axes position more than 3 mm is not recommended. Measure the height of the riflescope axis above the rail. If the difference in the axis heights of the PS-22 and riflescope is more than 3 mm it is necessary to replace riflescope mounting rings or base by proper ones.

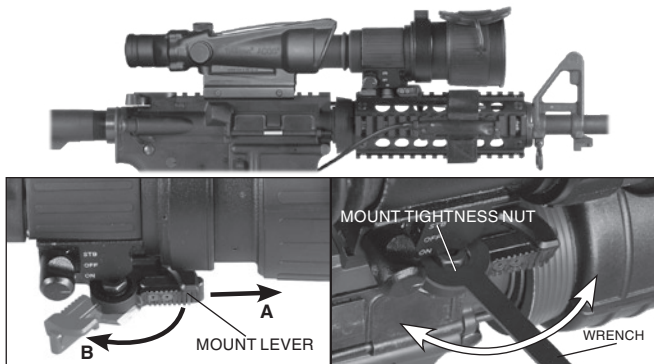

**FIGURE 2-1. PS-22 INSTALLED ON MIL-STD-1913 RAIL FORWARD OF TRIJICON ACOG**

1. Slide the locking button of mount lever forward (Figure 2-1, arrow A). Turn the mount lever backwards to open the mount (Figure 2-1, arrow B).
2. Install the sight forward the riflescope on the arm rail as close to the riflescope as possible. The light suppressor should cover the riflescope objective lens.
3. Turn the lever forwards pushing and sliding forward locking button to close the mount.

QR Mount comes factory set to securely fit most standard MIL-STD-1913/Picatinny mounts. However, there may be some slight differences in each mount from various manufacturers. You can loosen or tighten the QRM on your rail by using a 3/8" wrench and adjust the Mount Tightness Nut.

#### **NOTE**

**If using weaver rails, please consult your gunsmith for modification to rail.**

### **2.1.2. ATTACHMENT TO DAY SCOPE OBJECTIVE**

#### **CAUTION**

**The PS-22 will not attach to those riflescopes/spotting scopes which have their focusing ring on the hood of the objective lens bell.**

Optional Scope Mounting Systems are designed to install the PS-22 onto the riflescope/spotting scope objective lens.

The Scope Mounting Systems and their inserts differ in attaching diameters and are supplied on special order with account of the parameters of the scope. To choose the proper system # and its correspondent insert refer to the Table 2-1. For example, you will need the scope mounting system #1 and 25.4 mm insert in order to mount the PS-22 onto the front lens of Leupold 1.5-5x20 PR.

#### **NOTE**

**If scope mounting system is used, the issued weapon mount should be removed.**

Installation:

1. Loosen two screws M2x2.5 inside the locking ring (Figure 2-2) of the scope mounting system. The locking ring must travel easily along the thread.
2. Rotate the locking ring towards the body of the mounting system until full stop (the rotating direction is shown with arrow on Figure 2-2). Avoid overtightening.
3. Remove the Back Cap (or Light Suppressor, if it was installed) from the PS22 output lens and leave it in the storage case.
4. Screw the scope mounting system with insert inside into the PS22 output lens thread and hand-tighten it.



**FIGURE 2-2. SCOPE MOUNTING SYSTEM**

5. Loosen the fixing nut of the mounting system.
6. Slide the PS-22 with attached mounting system onto the objective lens of the day scope until full stop.

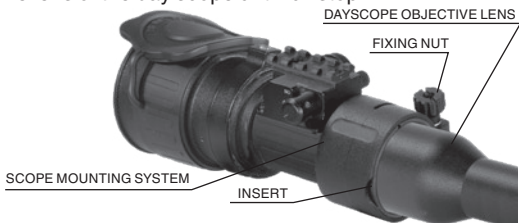

**FIGURE 2-3. PS22 INSTALLED ON DAYSCOPE OBJECTIVE LENS**



**FIGURE 2-4. ESTIMATION OF THE ANGLE WHICH THE SCOPE MOUNTING SYSTEM SHOULD BE TURNED THROUGH**

7. Align the seating of the PS22 and its mounting system on the day scope lens. Decide on the desirable position of the nut and turn the scope mounting system until you achieve it (see arrow in Figure 2-4).
8. Tighten the fixing nut hard with a screwdriver.
9. Now you may turn the PS22 unit to the optimal position (e.g. function switch placed strictly horizontal or canted), at your discretion.

10. Rotate the locking ring of the scope mounting system towards the PS22 output lens and tighten it. It will work as a lock nut to fix the PS22 position on the day scope.
11. Apply a small amount of thread locker on threads and tighten the two screws M2x2.5 in the locking ring.

**TABLE 2-1. SCOPE MOUNTING SYSTEMS**

<b>SCOPE MOUNTING SYSTEM #</b>	<b>OBJECTIVE LENS DIAMETER (INSERT SIZE), MM</b>	<b>CLEAR APERTURE OF OBJECTIVE LENS, MM</b>	<b>RIFLESCOPE MODEL</b>
1	25,4	25.4; 30	Leupold 1.5-5x20 PR
	30		Leupold 1.5-5x20 MR/T M2 Zeiss 1.1-4x24T
2	38	38; 42	Meopta Artemis 2000 4x32
	42		Leupold Mark 4 3-9x36 Leupold Mark 4 2.5-8x36 Kahles 4x36
3	42	42; 46.7; 48; 48.7-49; 49.5; 50	Leupold Mark 4 3-9x36 Leupold Mark 4 2.5-8x36 Kahles 4x36
	46,7		Leupold 3.5-10x40 Leupold VX-II 3-9x40
	48		Zeiss 1.5-6x42 Swarovski PV-N 2.5-10x42
	48.7-49		Meopta Artemis 3000 3-9x42
	49,5		Meopta Artemis 3000 4-12x40
	50		Shmidt & Bender 10x42
4	56	56; 57; 58.7	Zeiss 2.5-10x50
	57		Shmidt & Bender 3-12x50
	58,7		Leupold 4.4-14x50 Leupold VX-III 3.5-10x50
6	62	62	Zeiss 3-12x56
			Swarovski 2,5-10x56
			Kahles CSX 3-12x56



PS22 with QRM with Leupold Daytime Scope and IR450 on Platform Ring



PS22 with Leupold Daytime Scope with Scope Mounting System, Picatinny rail for IR450



PS22 with Leupold Daytime Scope with Scope Mounting System



PS22 with QRM and Trijicon ACOG



PS22 with Scope Mounting System and Leupold CQ/T



PS22 with Spotting Scope with Scope Mounting System

**FIGURE 2-5. PS-22 MOUNTING EXAMPLES**

### 2.1.3. EXTENDER FOCUS KNOB

If desired the PS22 has an optional extender focus knob that can be attached to the focus ring.

This knob allows for extra leverage for ease of focus adjustment.

To install the extender focus knob:

1. Unscrew the fixing screw. Replace it to short fixing screw(1) from extender focus knob kit. Screw the new fixing screw(1) to the lug and tighten it. Do not over tight it avoiding irregular rotation of the focus ring.
2. Place knob(2) on top of focus ring knob, insuring it is properly seated.
3. Tighten extender focus knob screw (3) until it is secure (do not over tighten).

To remove the extender focus knob:

1. Unscrew extender focus knob screw located on top of knob.
2. Remove extender focus knob.

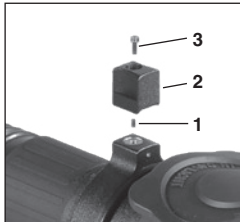

FIGURE 2-6. EXTENDER FOCUS KNOB

## 2.2. OPERATING PROCEDURES

---

### 2.2.1. GENERAL

This section contains instructions for placing the PS-22 in operation. The function of controls is explained.

#### **CAUTION**

**The PS-22 is a precision electro-optical instrument and must be handled carefully at all times.**

#### **CAUTION**

**Ensure the function switch is in the off position before installing a battery.**

### 2.2.2. CONTROLS

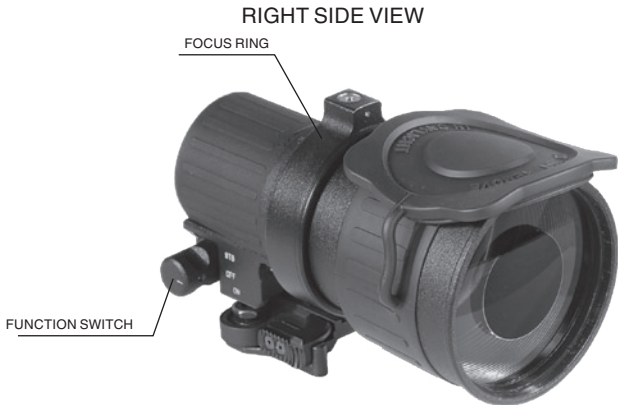

**FIGURE 2-7. PS-22 CONTROLS**

## REAR VIEW



**FIGURE 2-8. PS-22 CONTROLS**

**TABLE 2-2. PS-22 CONTROLS**

CONTROLS	FUNCTION
Function Switch	STB — the sight is in standby mode.
	OFF — the sight is off.
	ON — the sight is on. Switch's spring is loaded.
Focus Ring	Focuses the input lens. Adjusts for sharpest view of scene.
Remote control	Switches the sight from STB to operating mode.

### 2.2.3. OPERATING PROCEDURES

These procedures should be performed under night light conditions only.

#### **CAUTION**

**Use of the PS-22 under high light conditions may damage the image intensifier.**

1. Make sure the battery is installed as indicated on the sight body.
2. Make visual estimation of the illumination level in the viewing area using the reference data presented in Appendix A. You can start to operate with the sight if illumination level is less than 1 lux.
3. Remove the Front Lens Cap and place it over the lens housing.
4. Turn the power switch to the ON position. A green glow will appear in the scope eyepiece (after a slight delay).
5. Observe the scene and adjust focus rotating focusing ring to achieve sharp image.

#### **CAUTION**

**Bright sources such as light of fire, headlights, searchlights, etc. Can damage the PS-22.**

**Take away the PS-22 from the bright sources that appear on the scene.**

6. If the riflescope has focusing rings (parallax adjustment knob), adjust focus for parallax free image.
7. If the scope has reticle illumination, switch it on and adjust reticle brightness.
8. PS-22 Shut-Down:
  - a) Turn the function switch to OFF position. The green glow will disappear.
  - b) Replace the protective cover on the input lens.
  - c) If necessary remove the sight from the rail (from the scope lens) in reverse order of installing.

- d) Unscrew the battery cap and take out the battery. Replace the battery cap. Do not store the PS-22 with the battery still in it.
- e) Return the sight and all accessories to the case.

#### **2.2.4. STOWAGE OF PS-22**

1. Ensure the PS-22 and all accessories are clean and dry before returning to storage case.
2. Replace the objective cap and output cap on the lenses. Remove the battery.
3. Make sure the sight and accessories are stored in the appropriate locations in the case and close the cover.

## 2.3. INSTALLATION AND USE OF ACCESSORIES

---

### 2.3.1. 7/8" WEAVER MOUNT

Optional 7/8" Weaver Mount is used for installation the PS-22 on 7/8" Weaver rail instead of the issued mount.

#### **NOTE**

**If using weaver rails, please consult your gunsmith for modification to rail.**

1. Loosen and remove two screws M4x8 which secure the QR mount to the sight body. Remove the QRM.

#### **CAUTION**

**Use of screws longer than 8 mm will damage power switch.**

2. Put the Weaver Mount on the sight body. The mount nuts should be placed the same side as switch knob. Apply a small amount of thread locker on threads, install two screws M4x8 and tighten it.
3. Loosen the mount nuts. Install the sight onto the rail as close to the riflescope as possible. The light suppressor should cover the riflescope objective lens.
4. Tighten the mount nuts using screwdriver.



**FIGURE 2-9. ASSEMBLING PS-22 WITH 7/8" WEAVER MOUNT**

### 2.3.2. REMOTE CONTROL

Remote control is designed to operate the PS-22 in short-time activation mode.

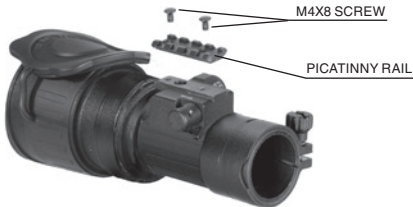

**FIGURE 2-10. REMOTE CONTROL**

1. Unscrew plug cap.
2. Attach the remote control socket to the plug on the sight body and screw the captive nut.
3. Place the control key on the fore-end of rifle stock and fix it with Velcro tape.
4. To turn on the PS-22 turn the function switch in standby (STB) position. Press and hold the control key.
5. After disconnecting the remote control screw the cap onto the plug.

### **2.3.3. PICATINNY RAIL**

Optional adapter rail is used for mounting the IR 450 illuminator on the PS-22 to provide supplementary infrared illumination when operating under extremely low light conditions.



**FIGURE 2-11. ASSEMBLING PS-22 WITH PICATINNY RAIL**

#### **NOTE**

The rail can be used if the PS-22 is installed on the dayscope lens using scope mounting system.

The rail is attached to the PS-22 body with two screws M4x8 instead of the issued mount (Figure 2-11).

### 2.3.4. PLATFORM RING

If the PS-22 is installed on MIL-STD-1913 rail, optional platform ring is used for mounting the IR 450 illuminator on dayscope with mounting diameter 25.4 or 30 mm.

Attach the platform ring to your dayscope as follows:

1. Unscrew the two screws from the platform ring. Use Allen wrench 2.5mm.
2. If the mounting diameter of your scope is 30 mm, remove plastic inserts.
3. Place the top and lower parts of the platform ring around the dayscope tube.
4. Tighten hard the two screws set using screwdriver.

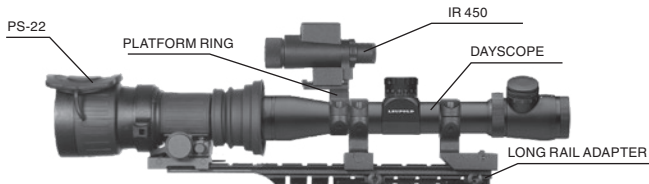

FIGURE 2-12. PLATFORM RING MOUNTED ON DAYSCOPE

### 2.3.5. LONG RAIL ADAPTER

Optional long rail adapter is used if the fire arm has short rail so that no place for installing the PS-22 forward of dayscope (Figure 2-12).

### 2.3.6. B.A.M. SYSTEM

B.A.M. system (Boresight Attachment Mount) is used to install the PS-22 Night Vision Front Sights and the dayscope on the rifles having short mounting MIL-STD-1913 rail.

There are three advantages of the system:

- Low position of the sight and dayscope (36 mm above the rail).
- Incline of the axis of the dayscope and the sight on 20 angular minutes for long range firing.

- Resistance on the rifle with vigorous recoil.

#### BAM System Installation:

1. Slightly loosen the two fixing screws (1) on the mount base (2).
2. Place the base on the mount of the fire arm (3).
3. Tighten the fixing screws of mount base.
4. Install the halves of plastic inserts (4) in the rings on the base.

#### **NOTE**

**There are two sets of inserts for scopes with 25.4mm and 30mm tubes diameter.**

5. Cradle the scope (5) in the rings (inserts).

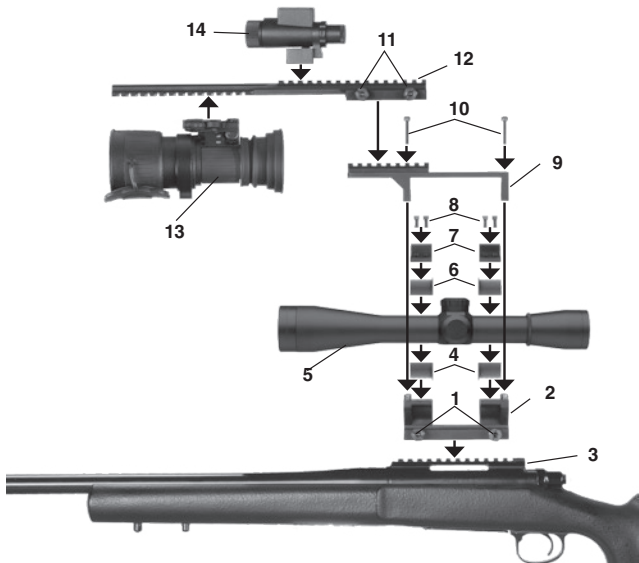

FIGURE 2-13. INSTALLATION OF B.A.M. SYSTEM

6. Install the top halves of the inserts (6) and the rings (7) and tighten each ring's four screws (8) to finger tight.
7. Install the top of the mount (9) and tighten four screws (10) to finger tight.
8. Slightly loosen the two fixing screws (11) on the top rail (12).
9. Place the top rail onto the Picatinny rail on the top of the mount.
10. Tighten the fixing screws of the top rail.
11. Place the Night Vision Front Sight (13) onto the top rail at front of the scope. The light suppressor of the front sight should cover the riflescope objective lens.
12. Place the infra-red illuminator (14) atop of the top rail.

You can quickly change your system back from night vision to day. Simply unscrew two fixing screws of the top rail and take off the top rail together with the front sight and IR illuminator.

#### **NOTE**

**The fixing screws may need to be tightened after continuous shooting.**

### **2.3.7. IR450 ILLUMINATOR**

Infra-red (IR) Illuminators are common for night vision technology. The IR light greatly enhances the performance of your device, while remaining almost totally invisible to the naked eye. Staying in the dark, switch on your night vision device. If the visibility is low, you may use ATN IR450 to improve the situation. Still, you should remember that the IR illuminator is just a source of infrared light so the greater is the chosen range of observation, the lesser its brightness becomes.

IR450 Infrared Illuminator can be mounted with PS-22 onto the Picatinny Rail, Platform Ring, BAM system or on to the weapon bases.

IR450 Installation:

1. Loosen the fixing nut of IR450.
2. Install the IR450 onto the Picatinny rail (Figure 2-5), BAM System (Figure 2-13) or Platform Ring (Figure 2-12).

### 3. Tighten the fixing nut of IR450 tightly.

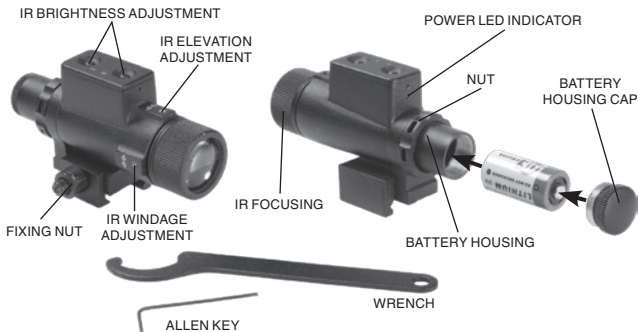

**FIGURE 2-14. IR450 ILLUMINATOR**

The ATN IR450 is powered with one CR123A lithium battery. To install the battery unscrew the cap of the battery housing and insert the battery following the polarity arrows marked on the housing. Put the cap in place.

The IR-450 illuminator has a control panel with two buttons. To switch the IR illuminator on/off press “+” and “-” buttons simultaneously. When the IR illuminator is switched on you can see the green LED lit on the back side of IR450. By pushing the buttons “+” and “-” you may adjust the IR brightness.

The IR beam is focusable to change the field of coverage. To change the beam width slightly turn the IR lens.

You may need adjust the focusing of the IR beam to change the field of coverage. Do it by slightly rotating the IR lens. The windage and elevation screws help adjust the direction of the IR beam from the IR450 in order to focus on the scene observed in the viewfinder of your NVD. Use the included Allen wrench to rotate the adjusting screws until the IR beam is centered. Please remember the adjustments should be performed under night light conditions only.

You can change the position of the IR control panel to meet your needs. The wrench that is included in the set, is used to loosen the nut located on the body of the IR. Rotate the IR to the desired position. Tighten the nut with the wrench to secure the new position.

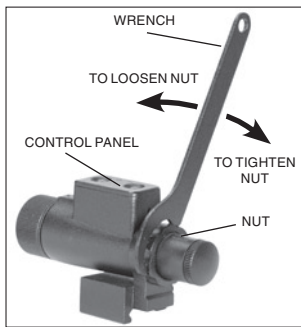

**FIGURE 2-15. CHANGING OF CONTROL PANEL POSITION**

### **2.3.8. DAY SCOPE LIGHT SUPPRESSOR**

To maximize usage of the PS-40 with a daytime scope a rubber light suppressor (DSLS) is included. The DSLS slides over the eyepiece of your daytime scope.

The DSLS was designed to achieve several missions:

1. Prevent back glow from the device that could give away position.
2. Prevent surrounding light from interfering with image on eyepiece.

The DSLS can be used with scopes that have 40...43mm eyepiece diameter and 100...120 mm eye relief.

The DSLS can be adjusted for the eye relief of your scope by cutting the rubber at the desired distance.



**FIGURE 2-16. DAY SCOPE LIGHT SUPPRESSOR**

## **SECTION III**

# **OPERATIONAL DEFECTS**

## 3.1. ZEROING OPERATIONAL DEFECTS

---

Operational defects refer to the reliability of the image intensifiers and are an evidence of instability. Their identification shall be a valid reason to immediately refuse to accept the ATN PS-22. These include shading, edge glow, flashing, flickering, and intermittent operation.

### 3.1.1. SHADING

If shading is persistent, you will not see a fully circular image (Figure 3-1). Shading is very dark and you cannot see an image through it. Shading always begins on the edge and migrates inward eventually across the entire image area. Shading is a high contrast area with a distinct line of demarcation. Contact ATN or point of purchase for warranty/repair procedures.

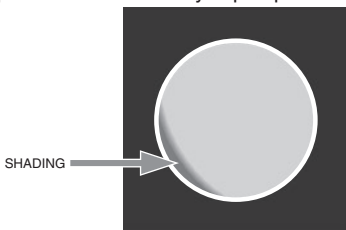

FIGURE 3-1. SHADING

#### **NOTE**

**Make sure the shading is not the result of improper exit pupil position.**

### 3.1.2. EDGE GLOW

Edge glow is a bright area (sometimes sparkling) in the outer portion of the viewing area (Figure 3-2). To check for edge glow, block out all light by cupping a hand over the lenses. If the image tubes are displaying edge glow the bright area will still show up. Contact ATN or point of purchase for warranty/repair procedures.

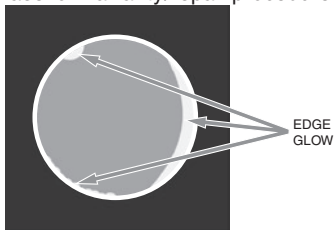

FIGURE 3-2. EDGE GLOW

### 3.1.3. FLASHING, FLICKERING, OR INTERMITTENT OPERATION

The image may appear to flicker or flash. If there is more than one flicker, check for loose battery adapter or weak battery. Contact ATN or point of purchase for warranty/repair procedures.

### 3.1.4. COSMETIC BLEMISHES

These are usually the result of manufacturing imperfections that do not affect image intensifiers reliability and are not normally a reason to claim for warranty or repair work. However, some types of blemishes can get worse over time and interfere with the usability of the device. If you believe a blemish is a cause for rejection, warranty or repair please ATN or point of purchase for warranty/repair procedures.

## A. Bright Spots

A bright spot is a small, non-uniform, bright area that may flicker or appear constant (Figure 3-3).

Not all bright spots make the ATN PS-22 rejectable. Cup your hand over the lenses to block out all light. If the bright spot remains, return the ATN PS-22. Bright spots usually go away when the light is blocked out. Make sure any bright spot is not simply a bright area in the scene you are viewing. Bright spots are acceptable if they do not interfere with the ability to view the outside scene.

## B. Emission Points

A steady or fluctuating pinpoint of bright light in the image area and does not go away when all light is blocked from the objective lenses of the Front Sight (Figure 3-3). The position of an emission point within the image area does not move. Not all emission points make the ATN PS-22 rejectable. Make sure any emission point is not simply a point light source in the scene you are viewing. Emission points are acceptable if they do not interfere with the usability of the device.

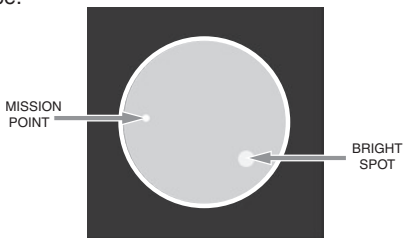

FIGURE 3-3. BRIGHT SPOTS AND EMISSION POINTS

### **C. Black Spots**

These are cosmetic blemishes in the image intensifiers or dirt or debris between the lenses. Black spots are acceptable as long as they do not interfere with viewing the image. No action is required if this condition is present unless the spots interfere with the usability of the device.

### **D. Fixed-Pattern Noise**

This is usually a cosmetic blemish characterized by a faint hexagonal (honeycomb) pattern throughout the viewing area that most often occurs at high light levels or when viewing very bright lights (Figure 3-4). This pattern can be seen in every image intensifier if the light level is high enough. This condition is acceptable as long as the pattern does not interfere with viewing the image and usability of the device.

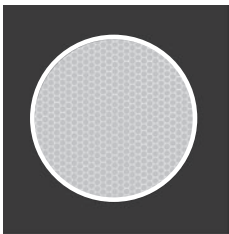

**FIGURE 3-4. FIXED-PATTERN NOISE**

### **E. Chicken Wire**

An irregular pattern of dark thin lines in the field of view either throughout the image area or in parts of the image area (Figure 3-5). Under the worst-case condition, these lines will form hexagonal or square-wave shaped lines. This is typically viewed in high light conditions. No action is required if this condition is present unless it interferes with the viewing the image and interferes with the users usability of the device.

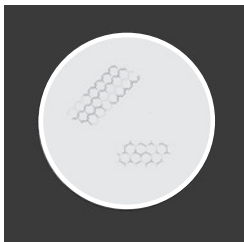

**FIGURE 3-5. CHICKEN WIRE**

## **SECTION IV**

# **MAINTENANCE INSTRUCTIONS**

# 4.1. PREVENTIVE MAINTENANCE CHECKS AND SERVICES (PMCS)

## 4.1.1. PURPOSE OF PMCS

PMCS is performed daily when in use to be sure that the sight is ready at all times. Procedures listed in Table 4-1 are a systematic inspection of the PS-22 that will enable you to discover defects that might cause the sight to fail on a mission.

## 4.1.2. PMCS PROCEDURES

The frequency of performing PMCS is as follows:

1. Daily when the sight is in use.
2. When it is removed from the case for any reason.

**TABLE 4-1. PREVENTIVE MAINTENANCE CHECKS AND SERVICES**

SEQ. NO.	ITEM TO CHECK	CHECKING PROCEDURE	NOT FULLY MISSION CAPABLE IF:
1	Completeness	Inventory items by means of comparing with the data specified in this manual.	Items missing.
2	Sight Body	Inspect for missing screws or connector cap.	Screws or connector cap missing.
3	Front Lens Cap	Inspect for cuts, tears and dirt. Clean as required.	Cap torn or cut.
4	Back Cap	Inspect for thread damage or dirt. Clean as required.	Thread damage hinder installation.
5	Battery Compartment	Check for corrosion, springs tension, cap damaged or retainer broken. Check O-ring for cuts or damage.	Springs corroded or damaged. Retainer broken. Cap or O-ring damaged or missing.
6	Function Switch	Check for operation (without battery).	Switch inoperative. Knob missing.
7	Lenses	Inspect for cleanliness, scratches, chips or cracks. Clean as required.	Chipped, cracked or if scratches hinder vision through the sight.

**TABLE 4-1. PREVENTIVE MAINTENANCE CHECKS AND SERVICES**

<b>SEQ. NO.</b>	<b>ITEM TO CHECK</b>	<b>CHECKING PROCEDURE</b>	<b>NOT FULLY MISSION CAPABLE IF:</b>
8	Objective Lens	Check to ensure the objective lens is not loose.	Objective lens loose.
9	Focus Ring	Check to ensure: — the focus ring cannot be moved along the sight body; — there is free rotation of the focus ring (more than 3/4 turn).	Focus ring able to move along sight body. Focus ring cannot be rotate.
10	Remote Control	Check cable and key for damage. Check Velcro tape for wear. Ensure the remote control connects to the sight plug securely.	Cable or key damaged. Velcro tape missing. Connector damage affects ability to connect remote control to the sight.
11	Light Suppressor	Inspect for cuts, tears or thread damage. Check ease of installation and removal.	Thread damage hinder installation. Suppressor torn or cut.
12	Mount Assembly	Check for damage or corrosion. Check for proper operation.	Mount body or axles damaged. Nuts missing.
13	Adapter	Inspect for damage.	Adapter damaged, screws missing.
14	Scope mounting system	Inspect for damage. Check to insure the ring is not loose. Check installation.	Thread or body damage hinder installation. Ring loosed. Insert or nut missing.
15	Installation security	Check the sight which installed on the arm rail or dayscope lens does not have any movement. Tighten fixing nuts if necessary.	

**TABLE 4-1. PREVENTIVE MAINTENANCE CHECKS AND SERVICES**

SEQ. NO.	ITEM TO CHECK	CHECKING PROCEDURE	NOT FULLY MISSION CAPABLE IF:
<p><b>OPERATIONAL CHECKS</b></p> <p><b><u>CAUTION</u></b></p> <p><b>Operate the PS-22 with Front Lens Cap on or under dark conditions.</b></p>			
16	Function Switch	Insert the battery. Turn the switch to ON position. Look for green glow in output lens. Turn the switch to OFF position.	Green glow absent.
17	Remote control	Connect the remote control to the sight. Turn the function switch to STB position. Press and hold the key. Look for green glow in output lens. Release the key; turn the switch to OFF position.	Green glow absent.
18	Viewed Image	Check for flickering, flashing, bright spots, edge glow, shading, excessive fixed-pattern noise (honeycomb).	Excessive cosmetic defects or fixed pattern noise.
<p><b>AFTER CHECKING PROCEDURES</b></p>			
19		Replace protective covers on the lenses. Disconnect the remote control and screw up the cap. Remove the battery. Return the sight and all accessories to the storage case.	

## 4.2. TROUBLESHOOTING

---

### 4.2.1. GENERAL

This section contains information for locating and removal most of the PS-22 operating troubles which may occur. Each malfunction for an individual component or assembly is followed by a list of tests or inspections that will help determine probable causes and corrective action to take. Perform the tests/inspections and corrective actions in the order listed.

This manual cannot list all possible malfunctions that may occur, or all tests or inspections and corrective actions. If a malfunction is not listed (except when malfunction and cause are obvious), or is not corrected by listed corrective actions, contact to the service center.

### 4.2.2. TROUBLESHOOTING PROCEDURES

Troubleshooting procedures are listed in Table 4-2.

**TABLE 4-2. TROUBLESHOOTING PROCEDURES**

<b>PROBLEM</b>	<b>PROBABLE CAUSE</b>	<b>CORRECTIVE ACTION</b>
Sight will not come on.	Battery is missing or improperly installed.	Insert battery or install correctly.
	Battery is dead.	Replace battery.
	Battery contact surfaces or contact springs dirty or corroded.	Clean the contact surfaces with a pencil eraser and/or alcohol and cotton swabs.
	Defective image tube.	Send the sight to the service center.

**TABLE 4-2. TROUBLESHOOTING PROCEDURES**

<b>PROBLEM</b>	<b>PROBABLE CAUSE</b>	<b>CORRECTIVE ACTION</b>
Cannot achieve the sharp image of the object.	Objective and output lenses dirty.	Clean thoroughly the lenses surfaces.
	Focus ring able to move along the sight body. Locking ring loose.	Loosen and remove three screws M2x2.5. Screw the locking ring. Rotate focus ring slightly clockwise/counterclockwise. Repeat all three times. Apply a small amount of thread locker on threads, install three screws M2x2.5 and tighten.
	Damaged optical components.	Send the sight to the service center.
Sight affects boresight after installation or during the firing.	Objective lens loose.	Screw objective lens up to the stop. Apply a small amount of thread locker on threads, install three screws M2.5x3 and tighten.
	Factory alignment broken.	Send the sight to the service center.
	Loose QRM mount	Adjust the cam latch nut to eliminate excessive play when mounted on the rail by using the provided wrench.

## **4.3. MAINTENANCE PROCEDURES**

### **4.3.1. PS-22 MAINTENANCE**

The PS-22 maintenance consists of external inspection of its components for serviceability, cleaning and installation of the standard and optional accessories. Maintenance instructions covered elsewhere in this manual (PMCS, troubleshooting, etc.) are not repeated in this section.

#### **CAUTION**

**The PS-22 is a precision electro-optical instrument and must be handled carefully at all times to prevent damage.**

### **4.3.2. CLEANING PROCEDURES**

#### **A. Cleaning of the PS-22**

1. Gently brush off any dirt from the sight body using only a clean soft cloth.
2. Moisten the cloth with fresh water and gently wipe the external surfaces (except lenses).
3. Dry any wet surfaces (except lenses) with another dry and clean soft cloth.
4. Using lens brush, carefully remove all loose dirt from the lenses.
5. Slightly dampen a cotton swab with ethanol and lightly and slowly wipe the lenses. Clean the glass surfaces by circular movements from the centre to the edge, not touching the lens holder and changing cotton swab after each circular stroke. Repeat this step until the glass surfaces are clean.

#### **B. Cleaning of Accessories**

Clean accessories with a soft brush (cloth) and soap and water as required.

#### **CAUTION**

**Dry thoroughly each item before replacing into the storage case.**

### 4.3.3. TUBE MAINTENANCE / REPLACEMENT

Tube maintenance/replacement is to be performed by qualified technicians only. These procedures attempted by non-qualified personnel will void warranty.

#### A. Tools and Equipment

Next tools are necessary for this procedure:

- Lock-ring spanner wrench;
- Focus wrench;
- Purge kit.

Table 4-3 lists requirements for the equipment needed for PS-22 focusing and aligning after tube replacement.

TABLE 4-3. EQUIPMENT FOR PS-22 FOCUSING AND ALIGNING.

ITEM #	ITEM	PARAMETER	REQUIREMENT
1	Collimator	Focal length	250 to 800 mm
		Exit pupil diameter	80 mm
		Focusing distance	Infinity
		Test pattern	Crosshair
		Pattern illumination	Daytime mode
			Nighttime mode
2	Mounting rail	Type	MIL-STD-1913
3	Telescope	Magnification	6 to 12
		Entrance pupil diameter	22 to 56 mm
		Focusing distance	Infinity
		Reticle	Crosshair

#### B. Tube Removal

- Loosen three fixing screws (Figure 4-1, 2).
- Unscrew and remove the objective lens (Figure 4-1, 1).
- Unscrew and remove the lock ring (Figure 4-1, 7).
- Draw out the spring washer («Glass/GLASS» tube only, Figure 4-1, 8).
- Take out defective image intensifier tube.

Below the actions for «GLASS/GLASS» tube only are listed:

- Accurately separate the compensator glass (Figure 4-1, 9) from the tube for second using.
- Unsolder tube wires from the board on the tube end (Figure 4-2). Accurately separate the board (Figure 4-2, 1) from the tube for second using.

### **C. Tube Installation**

«Glass/glass» tube preparation:

- Shorten tube wires up to 30 mm, strip insulation and tinning the wires.
- Bend tinning ends of the wires and solder it to the board according polarity marking on the tube body and the board.
- Align the board groove with the tube groove and glue the board (Figure 4-2, 1) onto the rear end surface of the tube (Figure 4-2, 2).
- Lay the wires into the tube groove and fix them with glue.
- Thoroughly clean the compensator glass.
- Apply small amount of glue on the glass and install it into the tube.

Tube installation:

- Thoroughly clean input and output windows of the tube.
- Insert the tube into the tube compartment. Be sure to engage the groove on the tube body with a pin in the tube compartment.
- Install the spring washer («Glass/GLASS» tube only, Figure 4-1, 8).
- Apply small amount of thread locker and screw the locking ring (Figure 4-1, 7). Do not over tighten it.
- Screw the objective lens (Figure 4-1, 1); put the lens cap (Figure 4-1, 6) on.

### **CAUTION**

**All testing and alignment procedures must be done in dark room (illumination level less than 0.3 Lx)**

## **NOTE**

If special attenuator filter is used, testing and alignment procedure could be done in the normal illuminated room and the collimator pattern illuminator could have only daytime mode. Attenuator filter have to be neutral glass filter with density 4 to 5. The filter effective diameter should be 63 mm and surface parallelism within 1 MOA. It is installed in the housing to mount on the sight.

### **D. Equipment Preparing**

- Provide coaxial position of the collimator, the sight and the telescope.
- Align the mounting rail with the collimator and fix it firmly. The angle between rail axis and collimator axis within 5 MOA.
- Adjusting angular position of the telescope match its crosshair with collimator crosshair.

### **E. Objective Lens Focusing**

- Switch the collimator pattern illuminator on in nighttime mode.
- Rotate the focus ring (Figure 4-3, 4) of the sight to achieve sharp image of collimator pattern.
- Check driving ring lug position (Figure 4-3, 8). The lug on the driving ring should be turn counterclockwise and a gap under the lug should be equal the thickness of your thumb.
- If the lug position is different, unscrew the screw (Figure 4-3, 11) and remove the extender focus knob (Figure 4-3, 10). Loose the fixing screw (Figure 4-3, 9) in the lug and rotate the driving ring to the right position. Tighten the fixing screw. Do not over tight it avoiding irregular rotation of the focus ring. Install the lever to the place.
- Rotate focus ring clockwise. The travel must be  $\frac{3}{4}$  of turn for focusing on close objects.
- If sharp image has not been achieved or focus ring can not be rotated  $\frac{3}{4}$  of turn, align the objective lens position as follows:
- Loosen three fixing screws (Figure 4-3, 5).
- Unscrew the lock ring (Figure 4-3, 6) and move it towards the battery compartment.

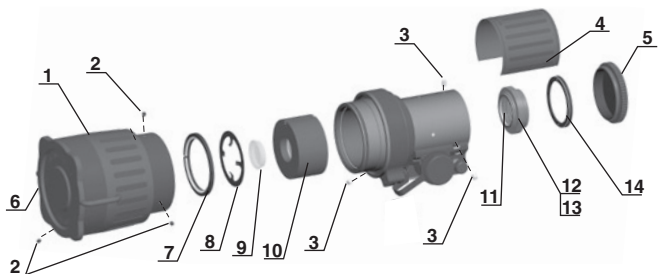

**FIGURE 4-1. TUBE REPLACEMENT**

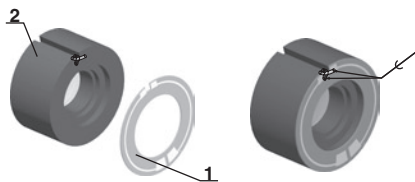

**FIGURE 4-2. INSTALLATION OF THE BOARD TO THE TUBE**

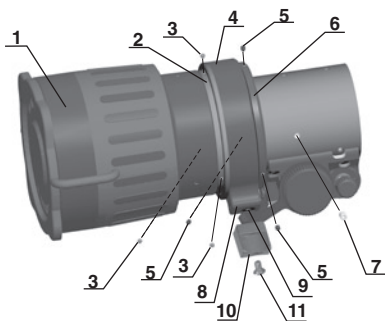

**FIGURE 4-3. OBJECTIVE LENS FOCUSING**

- Rotate the focus ring (Figure 4-3, 4) counterclockwise to open the objective thrust ring (Figure 4-3, 2). Not allow to fall the threaded segments out.
- Loosen three fixing screws (Figure 4-3, 3).
- Move the focus ring (Figure 4-3, 4) towards the objective lens.
- Rotate the objective lens (Figure 4-3, 1) and the thrust ring (Figure 4-3, 2) together to achieve sharp image of collimator pattern.
- Rotate the thrust ring (Figure 4-3, 2)  $\frac{1}{4}$  of turn counterclockwise and tighten fixing screws (Figure 4-3, 3) lightly.
- Unscrew fixing screws (Figure 4-3, 3) one by one, drill dimples through the holes in the ring, apply small amount of thread locker and secure the thrust ring with fixing screws.
- Rotate the focus ring (Figure 4-3, 4) clockwise up to the stop.
- Screw the lock ring (Figure 4-3, 6).
- Rotate the focus ring clockwise/counterclockwise three times.
- Tight the lock ring (Figure 4-3, 6) lightly.
- Unscrew fixing screws (Figure 4-3, 6) one by one, drill dimples through the holes in the ring, apply small amount of thread locker and secure the lock ring with fixing screws.
- Screw the objective lens (Figure 4-3, 1) up to the stop.
- Unscrew fixing screws (Figure 4-1, 2) one by one, drill dimples through the holes in the housing, apply small amount of thread locker and secure the objective lens with fixing screws.

## **F. Preparing the Sight For Alignment**

- Carefully separate the rubber cover (Figure 4-1, 4) from the sight body and remove it.
- Unscrew and remove the lock ring (Figure 4-1, 14).
- Loosen three adjusting screws (Figure 4-1, 3).
- Cut out old sealant and remove output lens assembly (Figure 4-1, 11).
- Thoroughly clean the output lens assembly and all internal surfaces of the unit including adjustment screws from sealant debris and any dirt.

- Replace the output lens assembly (Figure 4-1, 11) and tighten three adjustment screws (Figure 4-1, 3) lightly.
- Screw and tighten lightly the lock ring (Figure 4-1, 14).

### **G. Output Lens Focusing**

- Switch the collimator pattern illuminator on in nighttime mode.
- Put the sight onto the mounting rail, switch it on and rotate focus ring (Figure 4-3, 4) to achieve sharp image.
- Unscrew the output lens on 1.5- 2 mm and apply transparent glue or black primer.
- Rotate output lens (Figure 4-1, 11) with focus wrench to achieve parallax free image.

### **H. Boresight Alignment**

- Switch the collimator pattern illuminator on in daytime mode
- Without the sight, looking through the telescope check match- ing it's crosshair with collimator crosshair.
- Switch the collimator pattern illuminator on in nighttime mode.
- Put the sight onto the mounting rail, switch it on and rotate focus ring to achieve sharp image.
- Looking through the telescope, turn adjustment screws (Figure 4-1, 3) to match image of collimator crosshair with crosshair of the telescope.
- Switch the sight off and remove it from the rail.
- Unscrew and remove the lock ring (Figure 4-1, 14).
- Fill the gap between the output lens assembly (Figure 4-1, 11) and sight body with sealant.
- Screw the lock ring (Figure 4-1, 14) and tight it firmly.
- Check boresighting and correct if necessary.

### **I. Nitrogen Purge**

- Remove the purge screw (Figure 4-3, 7).
- Check airtightness of the sight and fill it with dry nitrogen.
- Apply small amount of sealant and install the purge screw.
- Put the rubber cover (Figure 4-1, 4) onto the sight body and secure it with glue.

# APPENDIX A

(Reference)

## ESTIMATION OF AMBIENT ILLUMINATION LEVEL

TABLE A-1. STANDARD NATURAL LIGHT CONDITIONS AND  
ILLUMINATION VALUES

STANDARD NATURAL LIGHT CONDITIONS	ILLUMINATION VALUE, LUX
Quarter moon	0.05
Full moon	0.30
Late twilight sky	1.00
Twilight sky	10.00
Overcast sky in the daytime	500.00

# APPENDIX B

## SPARE PARTS LIST

The Spare Parts List is an illustrated catalog of main parts and assemblies completing the Night Vision Sight PS-22, here in after referred to as PS-22.

Therefore, in case of failure of any part or assembly User could replace it by ordering the corresponding part/assembly from the Spare Parts List. The amount and assortment of the spare parts needed should be arranged with each contract individually.

**TABLE B-1. ATN PS-22 SPARE PARTS LIST**

<b>PART NO.</b>	<b>DESCRIPTION</b>	<b>FIG.</b>	<b>ITEM</b>
<b>AT 146541.700</b>	<b>Night Vision Sight</b>	<b>B1</b>	
AT 146541.701	Objective Assembly	B1	1
AT 146541.702	Objective Directive Screws	B1	2
AT 146541.703	Body (with Objective Focusing and Locking Rings)	B1	3
AT 146541.704	Objective Directive Screws	B1	4
AT 146541.705	Rubber Cover	B1	5
AT 146541.706	Back Cap	B1	6
AT 146541.707	Front Lens Cap	B1	7
AT 146541.708	Lock Ring	B1	8
AT 146541.709	Spring Washer	B1	9
AT 146541.710	Compensator Glass	B1	10
AT 146541.711	Image Intensifier Tube	B1	11
AT 146541.717	Lever	B1	12
AT 146541.718	Screw	B1	13
AT 146541.712	Rubber Cord	B1	14
AT 146541.713	Battery Cap	B1	15

**TABLE B-1. ATN PS-22 SPARE PARTS LIST**

<b>PART NO.</b>	<b>DESCRIPTION</b>	<b>FIG.</b>	<b>ITEM</b>
AT 146541.714	Plug Cap	B1	16
AT 146541.715	Output Lens Asseby	B1	17
AT 146541.716	Lock Ring	B1	18
<b>AT 146542.700</b>	<b>Accessories 1 (From the Kit)</b>	<b>B2</b>	
AT 146542.710	Light Supressor for the scopes with 42-63 mm lens diameter	B2	1
AT 146542.711	Light Supressor for Trijicon ACOG scopes	B2	2
AT 146542.712	Light Supressor for the scopes with 30-42 mm lens diameter	B2	3
AT 541002.702	QRM mount (with two M4x7 screws)	B2	4
AT 541002.713	Remote Control	B2	5
AT 146533.704	Picatinny Rail	B2	6
AT 146533.565	IR Illuminator IR450 Kit	B2	7
AT 146533.566	QRM Wrench	B2	8
AT 146533.567	2.5 mm Allen Key	B2	9
AT 541002.703	Operator's Manual	B2	10
AT 3187393	Shipping/Storage Case	B2	11
<b>AT 146533.700</b>	<b>Accessories 2 (Optional)</b>	<b>B3</b>	
AT 146533.751	Scope Mounting System #1	B3	1
AT 146533.752	Scope Mounting System #2	B3	1
AT 146533.753	Scope Mounting System #3	B3	1
AT 146533.754	Scope Mounting System #4	B3	1
AT 146533.755	Scope Mounting System #6	B3	1
AT 146534.751	Scope Mounting System Insert with 25.4 mm diameter	B3	2

**TABLE B-1. ATN PS-22 SPARE PARTS LIST**

<b>PART NO.</b>	<b>DESCRIPTION</b>	<b>FIG.</b>	<b>ITEM</b>
AT 146534.752	Scope Mounting System Insert with 30 mm diameter	B3	2
AT 146534.753	Scope Mounting System Insert with 38 mm diameter	B3	2
AT 146534.754	Scope Mounting System Insert with 42 mm diameter	B3	2
AT 146534.755	Scope Mounting System Insert with 46.7 mm diameter	B3	2
AT 146534.756	Scope Mounting System Insert with 48 mm diameter	B3	2
AT 146534.757	Scope Mounting System Insert with 48.7-49 mm diameter	B3	2
AT 146534.758	Scope Mounting System Insert with 49.5 mm diameter	B3	2
AT 146534.759	Scope Mounting System Insert with 50 mm diameter	B3	2
AT 146534.760	Scope Mounting System Insert with 56 mm diameter	B3	2
AT 146534.761	Scope Mounting System Insert with 57 mm diameter	B3	2
AT 146534.762	Scope Mounting System Insert with 58.7 mm diameter	B3	2
AT 146534.763	Scope Mounting System Insert with 62 mm diameter	B3	2
AT 146533.741	Long Rail Adapter	B3	3
AT 146539.701	7/8" Weaver Mount	B3	4
AT 146533.702	Platform Ring	B3	5
AT 146533.750	Extender Focus Knob	B3	6

**TABLE B-1. ATN PS-22 SPARE PARTS LIST**

<b>PART NO.</b>	<b>DESCRIPTION</b>	<b>FIG.</b>	<b>ITEM</b>
AT 146533.706	Day Scope Light Suppressor	B3	7
AT 146533.751	Boresight Attachment Mount (BAM)	B3	8

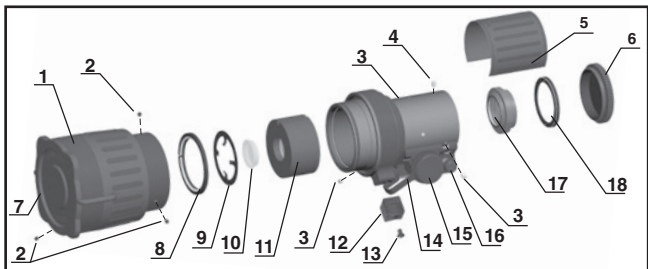

**FIGURE B-1. NIGHT VISION SIGHT**

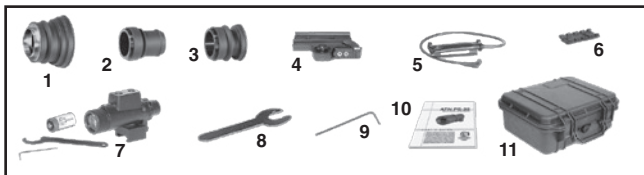

**FIGURE B-2. ACCESSORIES 1 (FROM THE KIT)**

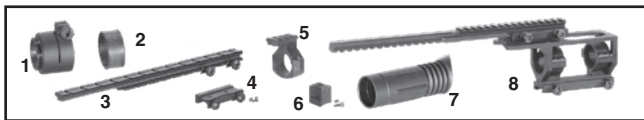

**FIGURE B-3. ACCESSORIES 2 (OPTIONAL)**

## APPENDIX C

### HOW TO SELECT SCOPE MOUNTING SYSTEM REQUIRED FOR YOUR DAYTIME SCOPE

By selecting the appropriate Scope Mounting System (with Inserts) you can mount the PS-22 onto a daytime scope with an objective tube diameter from 25 to 62 mm. At the Table 2-1 Scope Mounting System sizes (#1-6) and Insert sizes for different scope examples are provided.

If your specific daytime scope is not listed in Table 2-1, before mounting procedure you have to select the proper Scope Mounting System (and Insert) required.

To do this, perform the following actions:

1. Determine your daytime scope **objective tube diameter (external - not diameter of the glass lens)** with a millimeter ruler (with a trammel for more accurate results) as shown in figure C-1.
2. Select from the Table 2-1 the Insert size **closest (larger)** to the value measured (Insert size is also specified at an Insert body). Do the selection in Insert group that corresponds to the **same** Scope Mounting System (for example, Scope Mounting System #2).
3. The Scope Mounting System you need is the one that corresponds to Insert size selected at the Table 2-1.

For example, if your scope objective tube diameter is equal to 46 mm then you should select Insert with size of 46,7 mm and corresponding Scope Mounting Systems #3 from the Table 2-1.



**FIGURE C-1.**  
**OBJECTIVE TUBE DIAMETER  
MEASURING**

## FOR TECHNICAL INFORMATION

### **ATN CORP.**

1341 San Mateo Avenue  
South San Francisco, CA 94080  
(800) 910-2862  
(650) 989-5100 tel.  
(650) 875-0129 fax  
[www.atncorp.com](http://www.atncorp.com)  
[info@atncorp.com](mailto:info@atncorp.com)

18052011



For customer service and  
technical support, please contact  
American Technologies Network Corp.

**North American Office:**

1341 San Mateo Avenue  
South San Francisco, CA 94080

phone: 800-910-2862, 650-989-5100

fax: 650-875-0129

[www.atncorp.com](http://www.atncorp.com)